

# POWER

## BUZZER

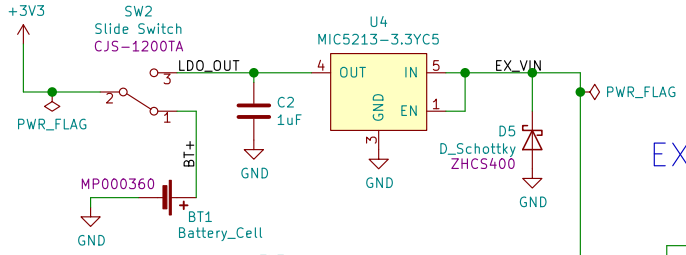

## EXTERNAL CONNECTOR

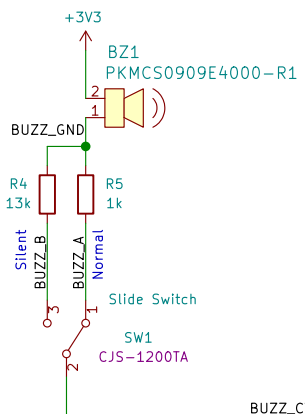
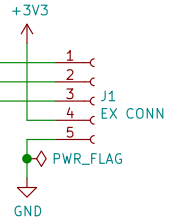

## EYES

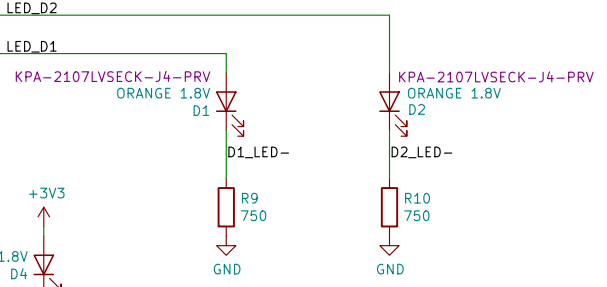

## BUTTON

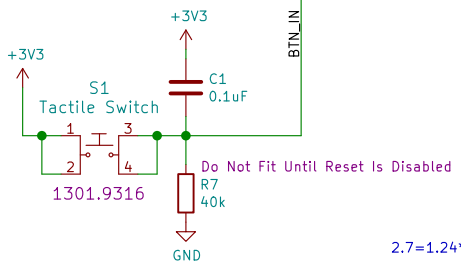

## LOW BAT LED

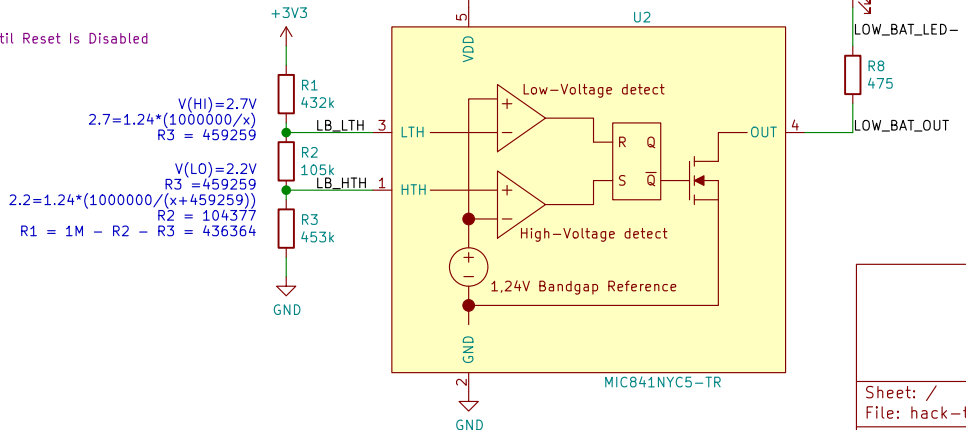

Sheet: /		Date:	
File: hack-the-crab.sch		Rev:	
Size: A4	KiCad E.D.A. kicad (5.1.4)-1	Id: 1/1	